

GRI 12 F

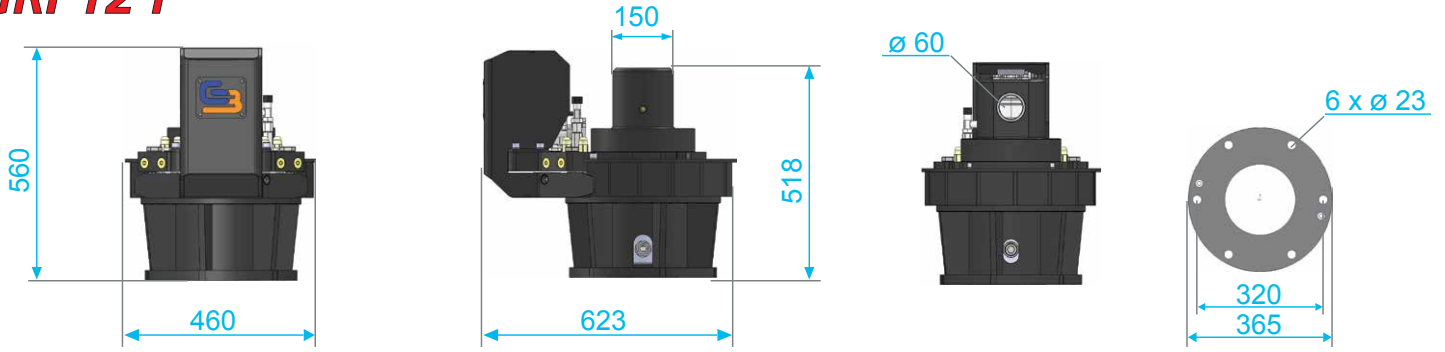

GRI 20 F

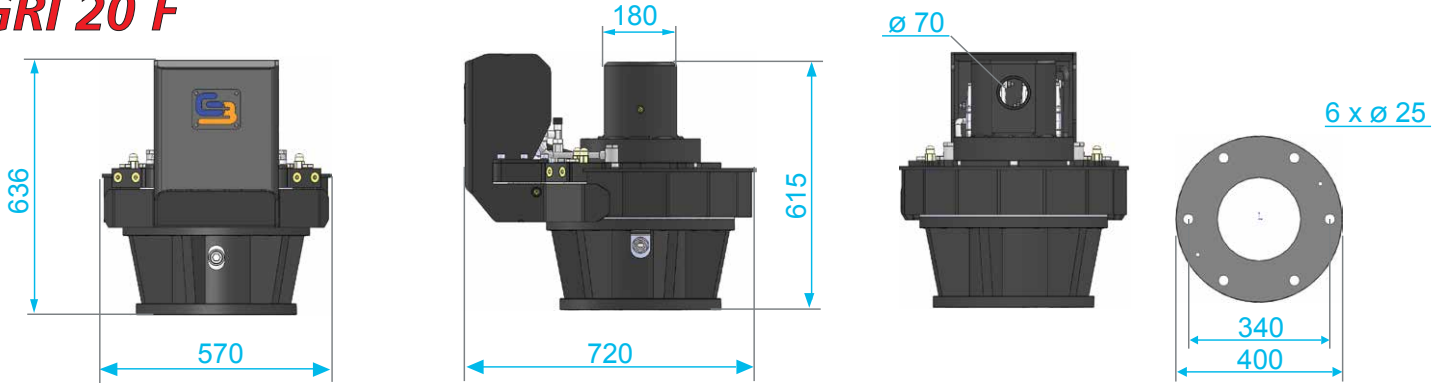

GRI 30 F

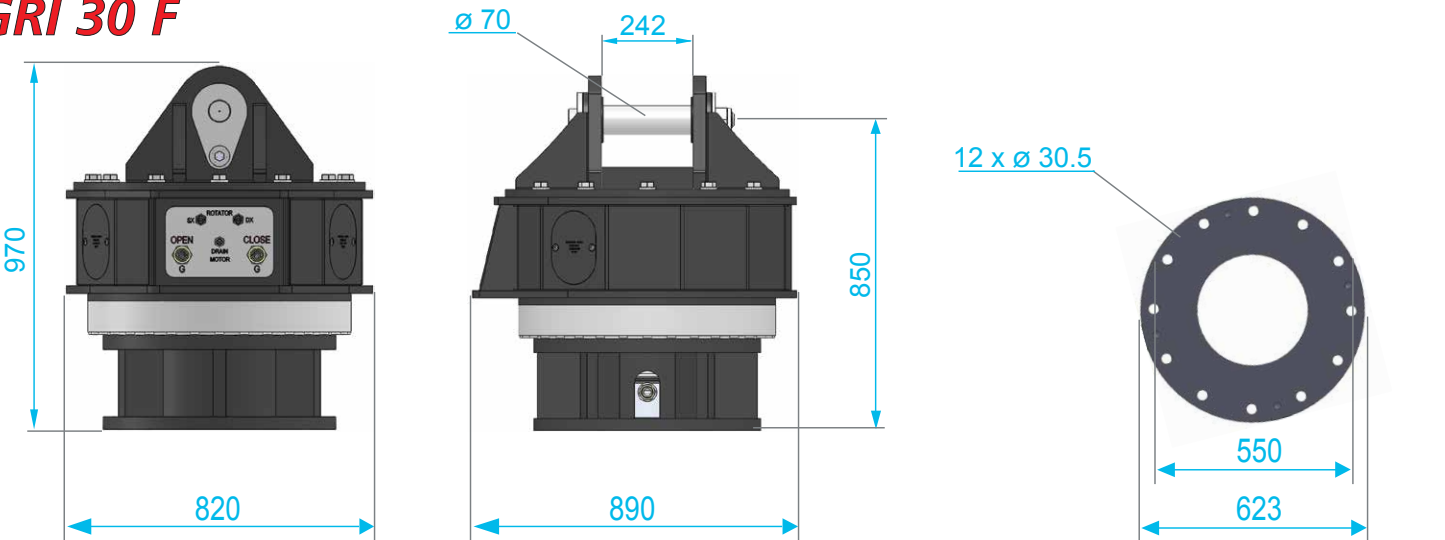

Model Modello	Max load Portata max	Torque Coppia	Engines Motori	Weight Peso	Rotation pressure Pressione rotatore	Grab pressure Press. attrezzatura	Max motor oil flow Flusso max oil motor	N° of revolutions N° di giri	Max grab oil flow Flusso max attrezz.
	Ton.	Nm.	Nr.	Kg.	Max Bar	Max Bar	Lt./min.	RPM	Lt./min.
GRI12 F	12	4900 (200Bar)	1	310	160	360	60	25	320
GRI20 F	20	7600 (200Bar)	2	370	200	360	120	40	320
GRI30 F	30	7600 (200Bar)	2	720	200	360	120	40	320



10041 Carignano (To) Italy
Via Cagliero, 17
Tel. +39 011 0133406

6662 NG Elst (Gld) Netherlands
Nijverheidsweg 6
Tel. +31 (0)481-374757

info@gusella-bakker.com



From Ton. 11,0

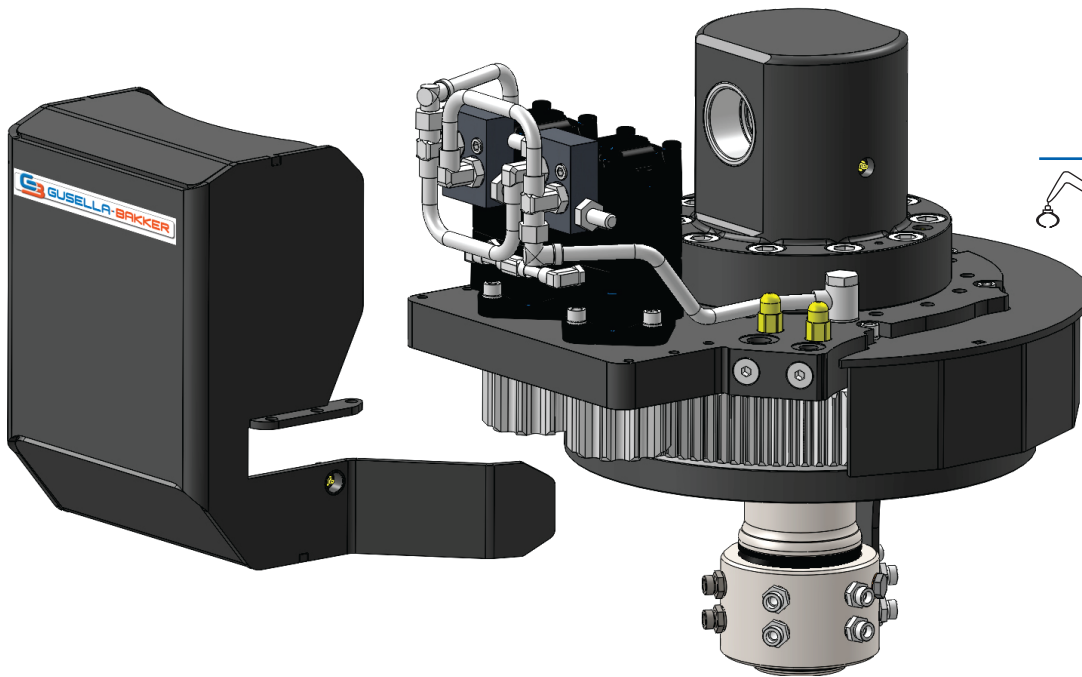

The GRI rotator consists of 7 structural parts assembled without welding.

Il rotatore GRI è composto da 7 elementi strutturali assemblati senza alcuna saldatura.

The oil passages have been fitted within the structure

I passaggi dell'olio sono stati ricavati all'interno della struttura.

Solid casings protect all the components from knocks and any materials which could damage the mechanical components.

Robusti carter proteggono tutti i componenti da urti ed eventuali materiali che potrebbero danneggiare i componenti meccanici.



To power the cylinders, we have created a special rotating distributor integrated into the rotator. By doing this we have got rid of the flexible tubes which connect the rotator to the grabs.

Per alimentare i cilindri, abbiamo creato uno speciale distributore rotante integrato nel rotatore. In questo modo abbiamo eliminato i tubi flessibili che collegano il rotatore all benne.