

# TIGERGRIP | TG 42 SM

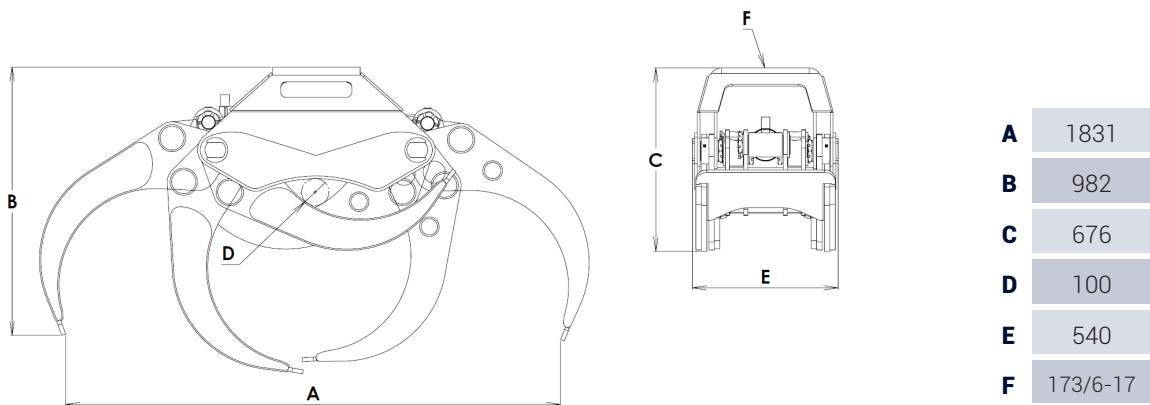

## KEY FEATURES

- Heavy duty
- Double guide bars
- Optimized roll in/roll out properties
- High pressure cylinder with double piston rod seals
- High tensile wear resistant steel (400 HB)
- Extra reinforced body for rigid mounting - excavator design



## MODEL SPECIFICATIONS



TG 42 SM	500	0,50	300	70	21,8	10	35	25	35			
----------	-----	------	-----	----	------	----	----	----	----	--	--	--

# INTERMERCATO

High performance lift and load attachments for Forestry, Transport, Construction and Recycling.

