

Gusella-Bakker Sales

10041 Carignano (To) Italy  
Via Cagliari, 17  
Tel. +39 011 0133406

 GUSELLA-BAKKER

6662 NG Elst (Gld) Netherlands  
Nijverheidsweg 6  
Tel. +31 (0)481-374757  
info@gusella-bakker.com

  
**SpiderKing**



## Designed to be the best

Nothing is left to chance. With our 50 years of Gusella Bakker know-how we took care of every single detail

No need to remove cylinders to change hoses

Fittings of the hoses are at the back of cylinders and therefore protected

Powder coating

Innovative design with rounded shape to avoid build-up of material

All conic pins to eliminate play (unique in the industry)

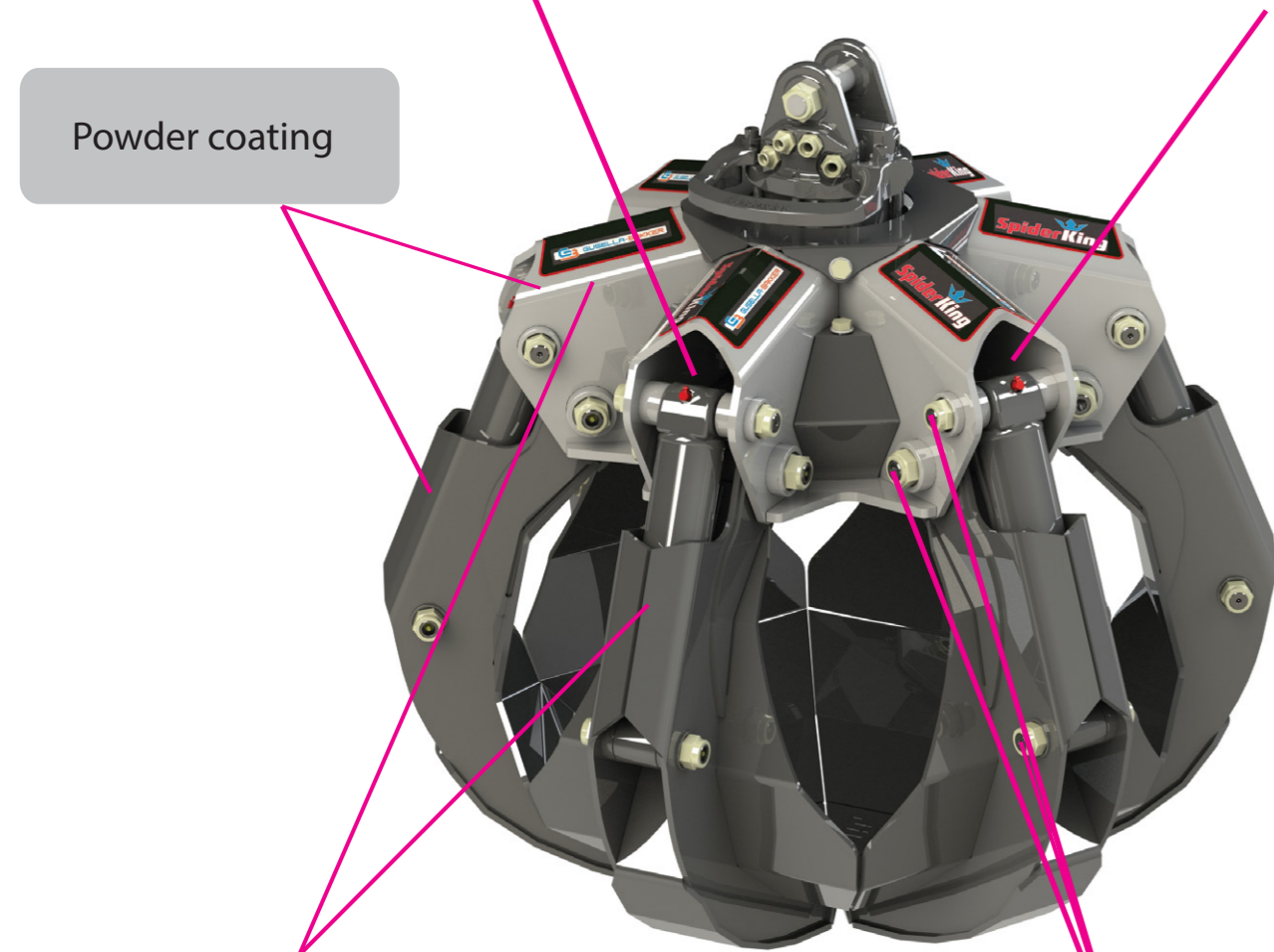

## Available as well in the Omega version

Omega, the first of its kind, sets the standard.

During the past 10 years Gusella-Bakker has developed the OMEGALINE orange peel grapple. This grapple features a special design to nest around so called "Z" cranes in folded position. The Spiderking is the best orange peel grapple in the market today for strength performance and safety.

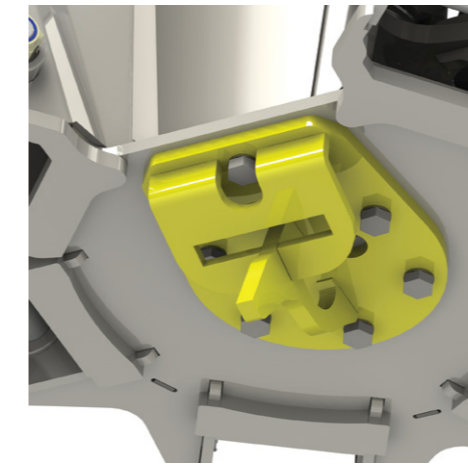
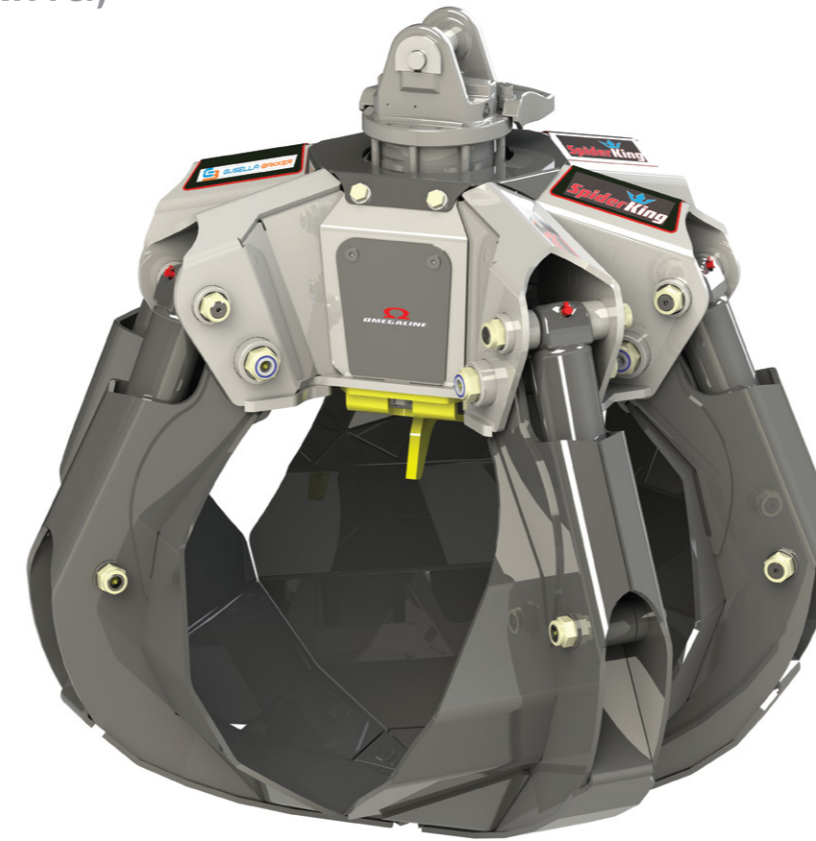
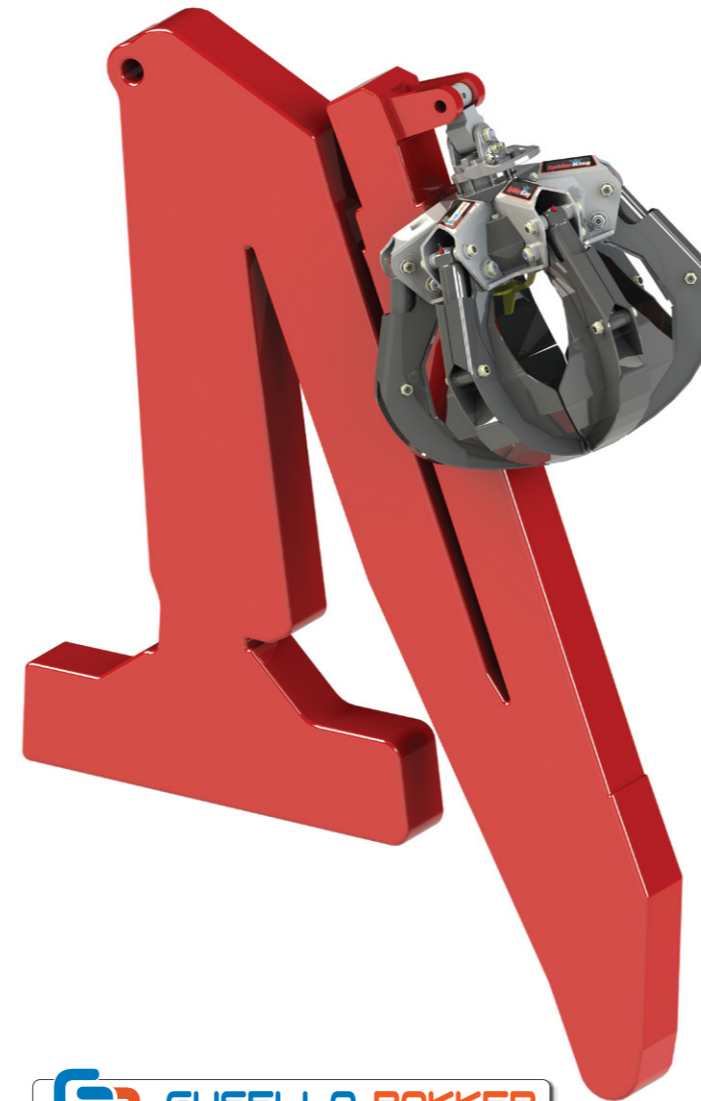

### Safety hook

Gusella-Bakker offers a new patented system of removable and adjustable clamps. Because of that the orange peel grapple can be customized to almost any loader

The first and only orange peel grapple available with conic pins for loader cranes!

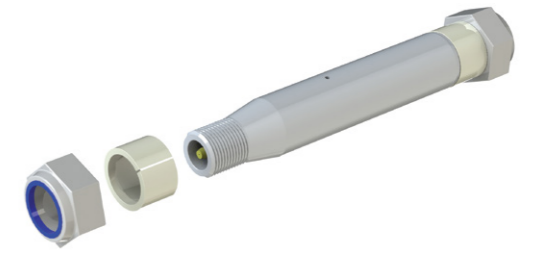

Pin of special hardened steel with nickel treatment

Bushings in special hardened wear resistant steel

Greaser is well protected inside the pin

Conic bushings in hardened steel

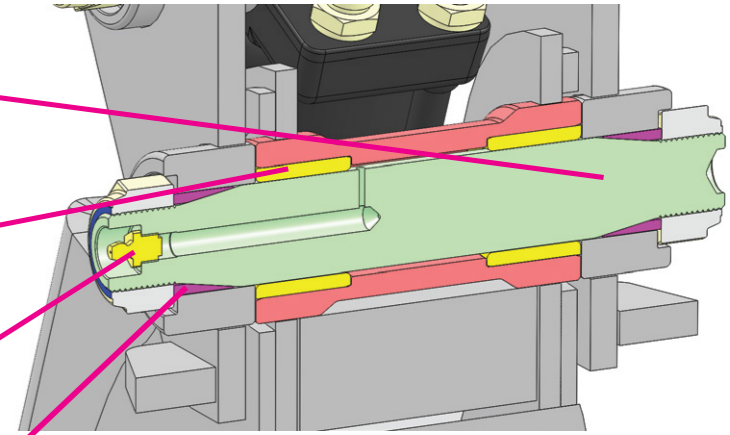

This system allows an easy elimination of play between pin and bushing caused by wear by tightening the nuts of the pin.



### Non return valve ICVS (optional)

Innovative ICVS special steel oil distributor that feeds cylinders. Non return valve is integrated in the oil distributor (unique in the industry)



### Tips

The tips of the Spiderking grapple are made from hot rolled wear resistant alloy steel.

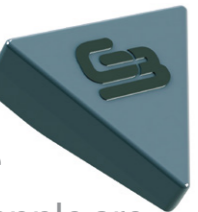

### Cylinders

High quality cylinders with casted cylinder head and special seals for fast movement

### Additional Protection

Corrosion-resistant nickel-zinc coating on all bare steel components

